

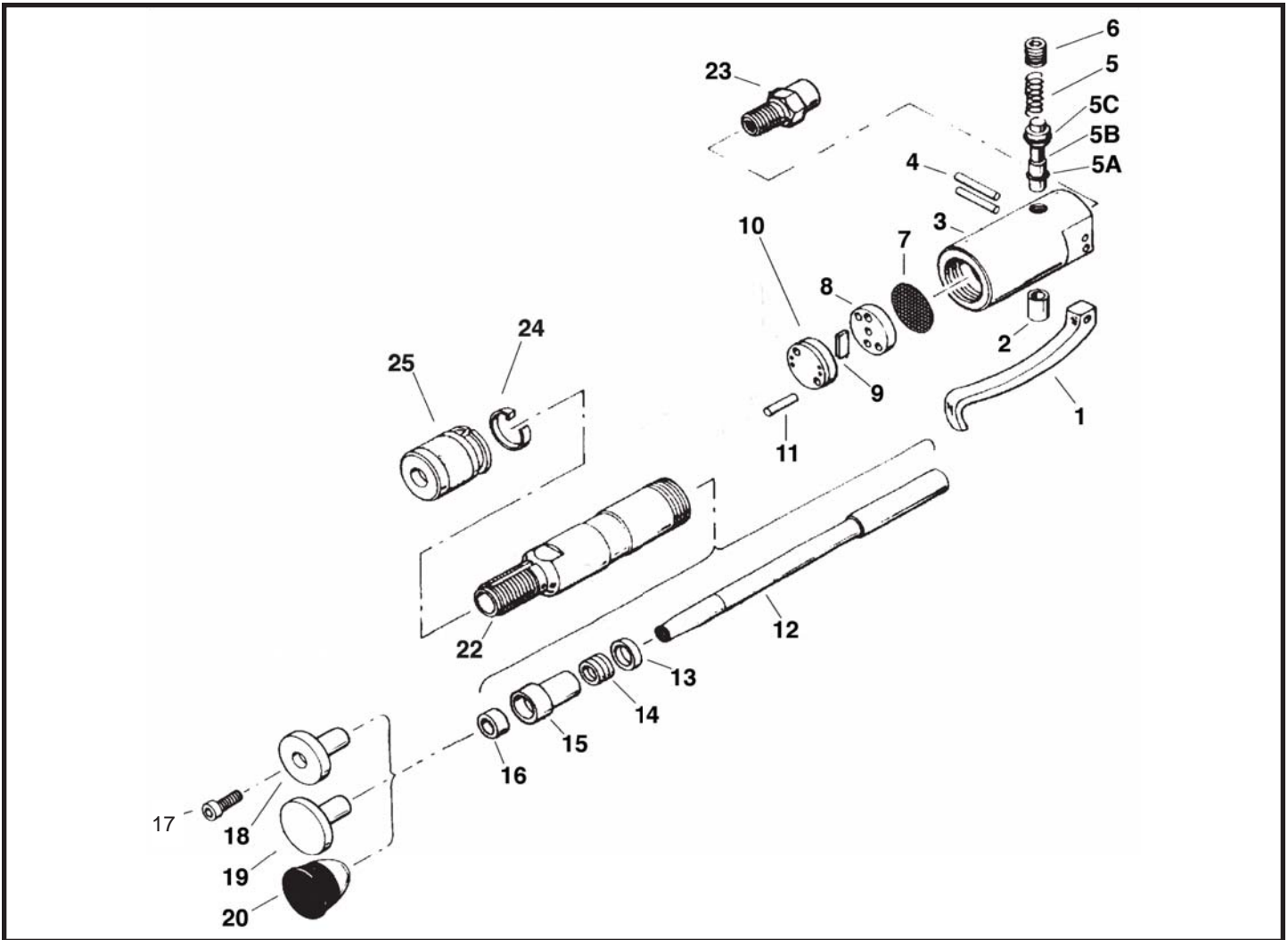

# SF-2BAR Rammer



Index	Part No.	Description	List Price
1	S5512-H	Lever	38.70
2	S5510	Throttle Bushing	8.30
3	S5501	Backhead	88.45
4	S5513	Lever Pin (2)	1.70
5	S5503	Throttle Spring	1.60
5A	SC-100	Stem O-Ring	.45
5B	S5511	Throttle Valve	16.35
5C		O-Ring	
6	S5502	Throttle Plug	6.25
7	S5504	Screen	2.05
8	S5505	Valve Lid	20.20
9	S5507	Valve	7.20
10	S5506	Valve Block	71.50

Index	Part No.	Description	List Price
11	S5508	Valve Dowel (2)	2.35
12	S5521	Piston (2-1/2")	108.75
13	S5517	Gland Washer	10.70
14	S5518	Packing Set	17.60
15	S5519A	Packing Gland(2-1/2")	17.60
16	S5524	Wiper Seal	10.85
17	S5530	Butt Screw	1.80
18	SR-5531	Steel Butt (2-1/2")	52.50
19	SR-251S	Rubber Butt (2-3/8")	42.60
22	S5515	Cylinder (2-1/2")	298.05
23	S5514	Screened Inlet	4.70
24	S5516	Lock Clip	10.70
25	S5520	Packing Nut	32.15

**\*\*ALL PRICING IS SUBJECT TO CHANGE WITHOUT NOTICE\*\***

Tamco Inc., ♦ 1466 Delberts Drive ♦ Monongahela, PA 15063 ♦ Tel: 1-800-826-2672 ♦ Fax: (724)258-6692

Visit Us Online At <http://www.TamcoTools.com>